

External Gear Pump

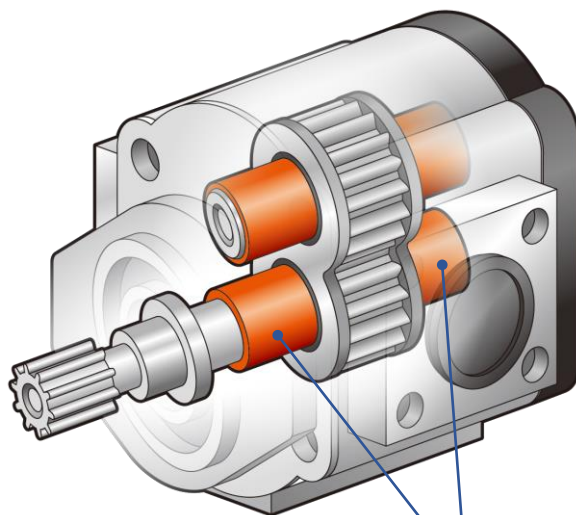

Cylindrical Bearing

RECOMMENDED MATERIAL

DDR17X

PTFE BASED BEARING



FEATURES

特長

- 1** Provides performance under high loads that is comparable to metal bearings.
金属材料に匹敵する高負荷能力を発揮します
- 2** Offers a low coefficient of friction and excellent wear resistance along boundary surfaces and under fluid lubrication.
境界および流体潤滑下で低摩擦係数と耐摩耗特性を持ちます
- 3** Eliminates “stick and slip” thanks to a low coefficient of friction.
低摩擦係数でスティック・スリップが起きません
- 4** Offers superior resistance to chemical substances.
耐薬品性に優れています
- 5** Performs well through an extended range of operating temperatures.
使用可能温度範囲が広範囲です

BEARING PERFORMANCE

性能

Seizure resistance 耐焼付性

